



**Australian Government**  
**Department of Industry, Science,  
Energy and Resources**

# **National Measurement Institute**

36 Bradfield Road, West Lindfield NSW 2070

## **Certificate of Approval NMI 5/6A/91B**

Issued by the Chief Metrologist under Regulation 60  
of the  
*National Measurement Regulations 1999*

This is to certify that an approval for use for trade has been granted in respect of the instruments herein described.

Compac Model MR40P Fuel Dispenser for Motor Vehicles

submitted by   Compac Industries Ltd  
                  52 Walls Road  
                  Penrose   Auckland   1061  
                  NEW ZEALAND

**NOTE:** This Certificate relates to the suitability of the pattern of the instrument for use for trade only in respect of its metrological characteristics. This Certificate does not constitute or imply any guarantee of compliance by the manufacturer or any other person with any requirements regarding safety.

This approval has been granted with reference to document NMI R 117 *Measuring Systems for Liquids Other than Water*, dated June 2011.

This approval is subject to review at the decision of the Chief Metrologist in accordance with the conditions specified in the document NMI P 106.

### DOCUMENT HISTORY

<b>Rev</b>	<b>Reason/Details</b>	<b>Date</b>
0	Pattern & variants 1 to 6 approved – interim certificate issued	15/12/05
1	Pattern & variants 1 to 6 approved – certificate issued	20/12/05
2	Variant 7 approved – certificate issued	19/12/07
3	Variants 8 & 9 approved – certificate issued	25/01/08
4	Variant 10 approved – interim certificate issued	30/04/08
5	Variant 10 approved – certificate issued	10/09/08
6	Pattern & variants 1 to 10 reviewed – notification of change issued	30/03/11
7	Variants 11 to 13 approved – certificate issued	18/05/11
8	Variant 14 approved – certificate issued	20/10/11

DOCUMENT HISTORY (cont...)

Rev	Reason/Details	Date
9	Pattern & variants 1 to 14 updated – variant 15 approved – certificate issued	9/11/12
10	Variant 16 approved – certificate issued	26/06/14
11	Variant 17 approved – certificate issued	31/03/15
12	Pattern & variants 1 to 17 reviewed – Pattern Amended (Any compatible NMI approved calculator/indicator) - certificate issued	21/01/19
13	Variant 8 amended (up to 100% ethanol) – Test procedure amended (hose configuration) – certificate issued	12/03/21
14	Variant 18 approved – certificate issued	17/11/21

CONDITIONS OF APPROVAL

**General**

Instruments purporting to comply with this approval shall be marked with pattern approval number 'NMI 5/6A/91B' and only by persons authorised by the submittor.

It is the submittor's responsibility to ensure that all instruments marked with this approval number are constructed as described in the documentation lodged with the National Measurement Institute (NMI) and with the relevant Certificate of Approval and Technical Schedule. Failure to comply with this Condition may attract penalties under Section 19B of the National Measurement Act and may result in cancellation or withdrawal of the approval, in accordance with document NMI P 106.

Auxiliary devices used with this instrument shall comply with the requirements of General Supplementary Certificates No S1/0/A or No S1/0B.

Signed by a person authorised by the Chief Metrologist to exercise their powers under Regulation 60 of the *National Measurement Regulations 1999*.



**Darryl Hines**  
Manager  
Policy and Regulatory Services

TECHNICAL SCHEDULE No 5/6A/91B

**1. Description of Pattern** **approved on 15/12/05**

A Compac Industries model MR40P fuel dispenser for motor vehicles (Figure 1) approved to dispense distillate and various grades of petrol, in attendant-operated mode, or in self-service mode when interfaced to a compatible (\*) approved self-service device.

(\*) 'Compatible' is defined to mean that no additions/changes to hardware/software are required for satisfactory operation of the complete system.

**1.1 Field of Operation**

The field of operation of the measuring system is determined by the following characteristics:

•	Minimum measured quantity, $V_{min}$	2 L	
•	Maximum flow rate, $Q_{max}$	40 L/min	
•	Minimum flow rate, $Q_{min}$	4 L/min	
•	Maximum pressure of the liquid, $P_{max}$	350 kPa	
•	Minimum pressure of the liquid, $P_{min}$	100 kPa	(#1)
•	Viscosity range of liquid (at 20°C)	0.5 to 20 mPa.s	(#2)
•	Maximum temperature of the liquid, $T_{max}$	50°C	
•	Minimum temperature of the liquid, $T_{min}$	-10°C	
•	Ambient temperature range	-25°C to 55°C	
•	Accuracy Class	0.5	

(#1) Minimum pressure for effective operation of gas elimination device.

(#2) Flowmeter is adjusted for use with one product viscosity.

**1.2 Hydraulic System**

The Compac Industries model MR40P fuel dispenser (Figure 2) comprises:

- (i) Either a ZHEJIAN MAIDE model ZYB-50CIL pumping unit or a Bennet Type 75 model 190701 pumping unit; the pumping unit incorporates an integral bypass, strainer and a gas elimination device, and is driven via a belt and pulley arrangement connected to an electric motor. Any vapour or gas separated by the gas separator is exhausted to the vent tube of the gas elimination device.
- (ii) A gas detection switch is connected to the vent tube on all units dispensing distillate, which stops the flow when an excessive amount of air/vapour is detected in the liquid.
- (iii) A rotary vane positive displacement measurement transducer (Figure 3) known as a Compac model COM-50 or COM-50S (S = with built-in non-linear correction), both flowmeters have an integral magnetic pulse generator.
- (iv) If a pre-set facility is used then a Parker Hannifin 19 mm valve, either a pulsed solenoid-operated valve or a two stage solenoid operated valve, is connected upstream of each hose to facilitate a pre-set delivery.

- (v) Either a type ZVA or type Xide 16 mm nozzle or any other compatible (#) approved nozzle connected to a Goodyear Flexsteel 559N 15.9 mm hose or any other compatible hose. The nozzle is the transfer device, which defines the start and stopping of the measured volume throughput, and is designed to maintain the hose full of liquid. The nozzle and its receptacle are designed so that the nozzle cannot be placed in a hang-up position other than to end the delivery.
- (vi) Optional price pre-setting facility (Figure 4) with 10 numerical keys ('0' to '9') and 2 function keys ('Fill' and 'Cancel') for pre-setting the price from \$1 to \$9999 dollars in \$1 increments. The pre-set facility incorporates a 4 digit LCD display for indicating the pre-set amount entered. Instruments incorporating pre-set facility have a model number with a '-P' suffix.

### 1.3 Calculator/Indicator

A Compac model C4000 calculator/indicator (Figure 5) or any other compatible (#) NMI-approved calculator/indicator, interfaced to the flowmeter with integral magnetic pulse output device generating pulses proportional to the volume throughput. The C4000 operates with software version P29232 when fitted to the pattern; refer to Tables 1 and 2 for the software versions used for other model fuel dispensers. The model C4000 comprises a processing circuit board and a separate display circuit board. Each processing board may be connected with up to four single or double-sided indicator boards.

The indicator board has two six-digit liquid crystal displays (LCD), one for volume and the other for total price, a four-digit unit price LCD and an electromechanical totaliser (Figure 6). The C4000 indicators display the following values:

Price:	\$0 000.00 to \$9 999.99 in 1 ¢ increments
Volume:	0 000.00 to 9 999.99 L in 0.01 L increments
Unit price:	0.000 to 9.999 \$/L in 0.001 \$/L increments
Totaliser:	0 000 000 L to 9 999 999 L in 1 L increments

The fuel dispenser may have the following alternative configurations of displays:

- Six-digit or seven-digit LCD (displaying the volume up to 9999.99 L or 99999.99 L, and displaying the price up to \$9999.99 or \$99999.99) and up to three four-digit or five-digit unit price LCD's displaying the unit price up to 9.999 \$/L or 99.999 \$/L for each grade of fuel (Figure 7).
- A volume only display comprising a six-digit or seven-digit LCD (displaying the volume up to 9999.99 L or 99999.99 L). This commercial version is without price and unit price displays and the instrument carries a notice stating "NOT FOR PUBLIC USE" (or similar wording) in capital letters not less than 6 mm high, either on or adjacent to each reading face (Figure 8).

#### Unit price setting:

The unit price may be changed by means of the parameter switch (marked 'SW1' in Figure 9) located on the C4000 processing circuit board. Alternatively it may be changed remotely when interfaced to a compatible NMI approved self-serve control device, in which case the parameter switch is also used to allocate the fuel dispenser number.

For any other compatible (#) NMI-approved calculator/indicator see the NMI-approval for details of unit price change and setting dispenser number.

#### Calibration Adjustment:

The following procedure is used to change the calibration k-factor on the C4000 calculator/indicator.

- (a) With the nozzle in its normal hung up position, press and release the k-factor switch (marked 'SW2' in Figure 9) in quick succession, until the desired setting is displayed.
- (b) Press and hold the k-factor switch; the 1st digit of the displayed setting will begin to increment. When the desired digit is displayed, release the k-factor switch.
- (c) Repeat step (b) until all digits of the desired k-factor are displayed.

Note: To view the software versions refer to the Test Procedure.

For any other compatible (#) NMI-approved calculator/indicator see the NMI-approval for calibration adjustment details.

- (#) 'Compatible' is defined to mean that no additions/changes to hardware/software specified in this approval are required for satisfactory operation of the complete system.

### 1.4 Checking Facilities

Removing the nozzle from its normal hang-up position initiates a segment check of the price, volume, and unit price displays.

- 'Air' is displayed and the delivery stopped if an excessive amount of air/vapour is detected
- 'Err 9' is displayed and delivery stopped when error in pulse output is detected

### 1.5 Totaliser

The instrument is fitted with an ENM Company model P2G729A, 4.5 V DC, electronic totaliser for indicating the volume totals in one litre graduations up to a maximum of 9 999 999 litres. The totaliser is located below the indicator.

### 1.6 Verification Provision

Provision is made for the application of a verification mark.

## 1.7 Markings

Instruments are marked with the following data, together in one location on a data plate:

Pattern approval sign	5/6A/91B
Manufacturer's identification mark or trade mark	.....
Manufacturer's designation (model number)	.....
Serial number	.....
Year of manufacture	.....
Maximum flow rate ( $Q_{max}$ )	..... L/min
Minimum flow rate ( $Q_{min}$ )	..... L/min
Maximum operating pressure ( $P_{max}$ )	..... kPa
Minimum operating pressure ( $P_{min}$ )	..... kPa
Nature of liquids to be measured	..... (*)
Environmental class	class C

(\*) e.g. distillate or D.

In addition, the minimum measured quantity ( $V_{min}$ ) shall be clearly visible on any indicating device visible to the user during measurement, in the form 'Minimum delivery 2 L'.

## 1.8 Sealing Provision

The gas separator test valve (Figure 10a), the meter (Figure 10b) and the calibration buttons on the calculator/indicator have provision for sealing. The calculator/indicator is sealed as described in its approval documentation (NMI S545 or any other compatible (#) NMI-approved calculator/indicator), including the K-factor (electronic calibration) switch, which is located on the indicator electronics board.

(#) 'Compatible' is defined to mean that no additions/changes to hardware/software specified in this approval are required for satisfactory operation of the complete system.

## 2. Description of Variant 1

approved on 15/12/05

The instrument in various configurations identified in Tables 1 and 2, including the following:

- In an alternative housing e.g. model L40P, LL40P (Figure 11), MMR40P, PR40P and PPR40P
- With up to 4 metering systems in the same housing e.g. model MR40PD (2 meters) and model MR40PQ (4 meters)
- Various models of the LEGEND series (Figure 12) as listed in Table 2

**3. Description of Variant 2** **approved on 15/12/05**

With one or more approved submersible turbine pump (STP) hydraulic systems (Figure 13). These hydraulic systems replace the equivalent components (i.e. motor, pump/strainer/gas separator, and associated pipework) in any fuel dispenser covered by this approval.

More than one fuel dispenser may be connected to the same STP provided the flow rate is greater than  $Q_{min}$  when all corresponding flowmeters are utilised at the same time.

A Parker Hannifin 19 mm valve, either a pulsed solenoid-operated valve or a two stage solenoid operated valve, is connected upstream of each hose to facilitate the pressurisation of the metering system and to control the delivery.

The model number of the pattern (MR40P) would become model MR40S.

**4. Description of Variant 3** **approved on 15/12/05**

With an external centrifugal or vane type pump installed in flooded suction and with the supply tank installed above ground (Figure 14). The supply tanks are fitted with a low level device which prevents measurements when the device is activated. The centrifugal or vane pump and the low level device replace the equivalent components in the fuel dispenser covered by this approval (i.e. motor, pump/strainer/gas separator, and associated pipe work).

The model number of the pattern (MR40P) would become model MR40S.

**5. Description of Variant 4** **approved on 15/12/05**

With a COM-25 flowmeter with built-in non-linear correction software.

The field of operation is the same as for the pattern except for the following:

- Maximum flow rate ( $Q_{max}$ ) is 40 L/min
- Minimum flow rate ( $Q_{min}$ ) is 4 L/min

**6. Description of Variant 5** **approved on 15/12/05**

With hydraulics modified for use with COM-125 flowmeter (Figure 15) incorporating two pumps connected in parallel (Figures 16 and 17) and using a ZVA 32 mm nozzle or any compatible approved nozzle connected to a Parker SKIVE 421-16 32 mm hose or any other compatible hose and may include a hose reel (Figure 18). A pump selector switch (Figure 19) is located in the vicinity of the nozzle hang-up; this enables the use of either one or two pumps depending on the flow rate required.

The model number of the pattern (MR40P) would become model MR160P.

The field of operation is the same as for the pattern except for the following:

- Maximum flow rate ( $Q_{max}$ ) is 80 L/min with a single pump selected or up to 160 L/min with both pumps selected
- Minimum flow rate ( $Q_{min}$ ) is 16 L/min
- Minimum measured quantity ( $V_{min}$ ) is 10 L

**7. Description of Variant 6** **approved on 15/12/05**

High flow version of the pattern with a model COM-50 or COM-50S flowmeter and using a ZVA 25 mm nozzle or any other compatible approved nozzle connected to a Parker SKIVE 421-16 25 mm hose or any other compatible hose and may include a hose reel (Figure 18).

These models are known as model MR80P or MR80S.

The field of operation is the same as for the pattern except for the following:

- Maximum flow rate ( $Q_{max}$ ) is 80 L/min
- Minimum flow rate ( $Q_{min}$ ) is 16 L/min
- Minimum measured quantity ( $V_{min}$ ) is 5 L

**8. Description of Variant 7** **approved on 18/12/07**

With a Parker Hannifin model IN FDW3525 filter installed downstream of the meter and outside the fuel dispenser housing (Figures 20 and 21). Instruments may also be known as Parker or RACOR units of the same model.

The filter may be installed on any model dispenser of this approval and used with any liquid hydrocarbon for which the dispenser is approved.

The filter unit is sealed to prevent any drainage of the product between the inlet of the filter and the nozzle of the fuel dispenser.

The maximum permissible errors applicable are those applicable to the fuel dispenser to which the instrument approved herein is fitted.

When the filter is changed the system is required to be primed with liquid up to the nozzle, and then the filter is to be sealed.

If a filter is installed after the fuel dispenser has been verified, then the dispenser must be tested and certified again after the filter has been installed. Similarly if the filter is removed then the dispenser must again be tested and certified.

A destructible adhesive label should be applied after verification.

**9. Description of Variant 8** **approved on 24/01/08**  
**amended on 12/03/21**

The pattern and variants for use to dispense various grades of petrol which may include up to 100% ethanol ('E100')

**10. Description of Variant 9** **approved on 24/01/08**

The pattern and variants constructed for use to dispense various grades of pure biodiesel and biodiesel/distillate blends (to Australian government standard).

**NOTE**

In addition to the markings as set out in clause **1.8 Markings**, instruments purporting to comply with variants 8 or 9 may need to carry other markings as required by government authorities other than the National Measurement Institute.



## 11. Description of Variant 10

approved on 30/04/08

With hydraulics described for variant 5 now modified and housed in a box to be placed underground (Figure 22).

The hydraulics include a model COM-125 flowmeter supplied by submersible pumps, and a ZVA 32 mm nozzle (or any compatible approved nozzle) connected to a Parker SKIVE 421-16 32 mm hose (or any other compatible hose). The system may include a hose reel.

A selector switch (when fitted) is typically located in the vicinity of the nozzle holder; this enables the use of either one or two solenoid valves depending on the flow rate required.

The model number of dispensers with underground hydraulics have a 'UR' prefix, e.g. UR160S or UR160SD: UR means 'underground commercial', 1 or 2 meters, 1 computing unit, and 1 or 2 displays.

The field of operation is the same as for the pattern except for the following:

- Maximum flow rate ( $Q_{max}$ ) is 80 L/min with a single pump selected or up to 160 L/min with both pumps selected
- Minimum flow rate ( $Q_{min}$ ) is 8/16 L/min
- Minimum measured quantity ( $V_{min}$ ) is 5/10 L

## 12. Description of Variant 11

approved on 17/05/11

Certain multiple product dispensers as described below:

- (a) Compac model MMA30-40S dual hose dispenser with one hose dispensing Diesel Exhaust Fluid (DEF) (aka AUS32 - aqueous urea solution 32.5%) and the other hose dispensing diesel/biodiesel (refer to variant 4) at a maximum flow rate of up to 40 L/min.
- (b) Compac model MMA30-80S dual hose dispenser with one hose dispensing Diesel Exhaust Fluid (DEF) and the other hose dispensing diesel/biodiesel (refer to variant 6) at a maximum flow rate of up to 80 L/min.
- (c) Compac model MMA30-160S dual hose dispenser with one hose dispensing Diesel Exhaust Fluid (DEF) and the other hose dispensing diesel/biodiesel (refer to variant 5) at a maximum flow rate of up to 160 L/min. +

For the C4000 calculator/indicator, the software number 29254 will be displayed when the parameter switch is pushed. For any other compatible (#) NMI-approved calculator/indicator see the NMI-approval.

For DEF measuring systems, the measurement transducer is a Compac model KG-40 coriolis principle mass flowmeter which provides electrical pulse output proportional to liquid throughput (Figure 23).

## 12.1 Field of Operation

The field of operation of the Diesel Exhaust Fluid (DEF) measuring systems are determined by the following characteristics:

- Minimum measured quantity,  $V_{min}$  2 L
  - Maximum flow rate,  $Q_{max}$  30 L/min
  - Minimum flow rate,  $Q_{min}$  3 L/min
  - Maximum pressure of the liquid,  $P_{max}$  320 kPa
  - Minimum pressure of the liquid,  $P_{min}$  50 kPa
  - Dynamic viscosity (at 25°C) 1.4 mPa.s (#)
  - Maximum temperature of the liquid,  $T_{max}$  30°C
  - Minimum temperature of the liquid,  $T_{min}$  0°C
  - Ambient temperature range -25 to 55°C
  - Accuracy class 0.5
- (#) The DEF flowmeter is adjusted to be correct for Diesel Exhaust Fluid (aka AUS32 - aqueous urea solution 32.5%) for which it is to be verified.

For DEF measuring systems, the instrument (Figure 23) incorporates the following components:

- (i) With an external centrifugal or vane type pump installed in flooded suction and with the supply tank installed above ground. The supply tank is fitted with a low level device which prevents measurements when the device is activated.
- (ii) A measurement transducer comprising a Compac model KG-40 coriolis principle mass flowmeter which provides electrical pulse output proportional to liquid throughput (Figure 24).
- (iii) A hose/nozzle, mounted on the side of the dispenser housing. The nozzle used is an Elaflex ZVA 16 mm; the hose used is an Elaflex DEF 16 mm of 6 metres maximum length.
- (iv) A Parker model 7221 direct lift stainless steel solenoid valve is used.

## 13. Description of Variant 12 approved on 17/05/11

For use with a remote nozzle holder and a remote display allowing mobile delivery systems to use the dispenser inside a separate housing with the display and nozzle on the outside of that housing – the display on the dispenser may be retained or removed. This variant may be used with a high mast (Figure 25a) or a hose reel (Figure 25b).

## 14. Description of Variant 13 approved on 17/05/11

With a Compac model DCA ('Driveway Card Acceptor') card-operated control system (as described in the documentation of approval NMI S454) mounted on top of the dispenser indicator (Figure 26) and known as the ComFutra option. The ComFutra is used in unattended self-service operation for registered users only. The 'Litres Total' electronic display is an individual user's total and is displayed as an 8 digit number to two decimal places (maximum 999999.99 L).

For the C4000 calculator/indicator, the software number 29255 will be displayed when the parameter switch is pushed. For any other compatible (#) NMI-approved calculator/indicator see the NMI-approval.

**15. Description of Variant 14**

**approved on 20/10/11**

With a Compac model DCA ('Driveway Card Acceptor') card-operated control system (as described in the documentation of approval NMI S454) mounted on top of the dispenser (Figure 27) and known as the Cardking option. The Cardking is used in unattended self-service operation. It includes a card reader (or other authorisation device) and a receipt printer.

The battery backup supply is not the same as the standard DCA model. It is a purpose-built supply using a 12 V, 7 AH, sealed lead acid battery. It has capacity to complete a transaction upon a mains power failure. The pump cannot be authorised while there is a mains power failure.

**16. Description of Variant 15**

**approved on 9/11/12**

The following models have two sets of hydraulics housed in a common chassis as described below:

- (a) Compac model MMR400-80S dual hose dispenser with one side using hydraulics components as described in NMI 5/6B/208 and the other side using hydraulics components as per the pattern.

With the following field of operation:

- Maximum flow rate ( $Q_{max}$ ) is 80 L/min
- Minimum flow rate ( $Q_{min}$ ) is 16 L/min
- Minimum measured quantity ( $V_{min}$ ) is 5 L

- (b) Compac model MMR400-160S dual hose dispenser with one side using hydraulics components as described in NMI 5/6B/208 and the other side using hydraulics components as per the pattern.

- Maximum flow rate ( $Q_{max}$ ) is 160 L/min
- Minimum flow rate ( $Q_{min}$ ) is 16 L/min
- Minimum measured quantity ( $V_{min}$ ) is 10 L

For the C4000 calculator/indicator, the software version number HIA-29263 or HIG-29263 will be displayed when the parameter switch is pushed. For any other compatible (#) NMI-approved calculator/indicator see the NMI-approval.

**17. Description of Variant 16**

**approved on 26/06/14**

The Compac model LLA30-160SQ four hose fuel dispenser with two hoses dispensing Diesel Exhaust Fluid (DEF) (aka AUS32 – aqueous urea solution 32.5%) and two hoses dispensing diesel/biodiesel subject to the relevant Field of Operation below.

### 17.1 Field of Operation

The DEF dispenser is described in approval NMI 5/6A/223 and in variant 11 of this approval, and has the following field of operation:

- Maximum flow rate ( $Q_{max}$ ) is 30 L/min
- Minimum flow rate ( $Q_{min}$ ) is 3 L/min
- Minimum measured quantity ( $V_{min}$ ) is 2 L

The diesel/biodiesel dispenser is described in in variant 5 of this approval, and has the following field of operation:

- Maximum flow rate ( $Q_{max}$ ) is 160 L/min
- Minimum flow rate ( $Q_{min}$ ) is 16 L/min
- Minimum measured quantity ( $V_{min}$ ) is 10 L

For the C4000 calculator/indicator, The software version number HIA-29265 or HIG-29265 will be displayed when the parameter switch is pushed. For any other compatible (#) NMI-approved calculator/indicator see the NMI-approval.

### 18. Description of Variant 17

**approved on 31/03/15**

For use with one or more Compac model V50 coriolis principle mass flowmeters (Figure 19) which provide a Modbus RS485 output to the calculator/indicator. This data is safeguarded with a CRC checksum over the data package.

Software for the C4000 calculator/indicator using the V50 flowmeter is versions 29600 and 29601. For any other compatible (#) NMI-approved calculator/indicator see the NMI-approval.

If air is detected the dispenser will stop the transaction flashing 'Air' on the display. This allows for the use of an above tank suction pump with this meter.

### 19. Description of Variant 18

**approved on 17/11/21**

With fuel dispenser models using the Compac model COM-50 and COM-125 flowmeters now constructed with an anodised aluminium meter housing (figure 41).

**TABLE 1**

Approved single or dual product type model designation and their meanings.

*	HOUSING TYPE:
L	Retail, 1 or 2 meters, 1 computing unit, 1 or 2 displays.
LL	Retail, 2 or 4 meters, 1 computing unit, 2 or 4 displays.
MR	Commercial, 1 or 2 meters, 1 computing unit, 1 or 2 displays.
MMR	Commercial, 2 or 4 meters, 1 computing unit, 2 or 4 displays.
PR	Commercial, 1 or 2 meters, 1 computing unit, 1 or 2 displays.
PPR	Commercial, 2 or 4 meters, 1 computing unit, 2 or 4 displays.
*	MAXIMUM NOMINAL FLOW RATE:
40	40 L/min.
80	80 L/min.
160	160 L/min.
*	PUMP TYPE:
P	Internal pump.
S	Submersible turbine pump (STP), or centrifugal or vane pump for above ground installations.
PD	1 internal pump, 2 meters (single suction, dual hose).
SD	Submersible turbine pump (STP), dual hose.
PQ	2 internal pumps, 4 meters (dual suction, quad hose).
SQ	Submersible turbine pump (STP), 4 meters (dual suction, quad hose).
*	OPTIONS:
	Various codes for options, e.g. pre-set (-P).

e.g. MR40P (the pattern)

Software versions: P29237 for models \*\*\*\*PQ and \*\*\*\*SQ; and  
P29232 for all other models

TABLE 2

Approved LEGEND series model designations and their configurations.

MD2	2 meters, 1 computing unit, 2 displays, submersible turbine pump (STP). (*)
MP2	2 meters, 1 computing unit, 2 displays, internal pump. (*)
MD4N	4 meters, 1 computing unit, 2 displays, submersible turbine pump (STP). (*)
MP4N	4 meters, 1 computing unit, 2 displays, 2 internal pumps. (*)
MD4	4 meters, 1 computing unit, 2 displays, submersible turbine pump (STP). (#)
MP4	4 meters, 1 computing unit, 2 displays, 2 internal pumps. (#)
MD6	6 meters, 2 computing units, 2 displays, submersible turbine pump (STP). (#)
MD6-1	6 meters, 1 computing unit, 2 displays, submersible turbine pump (STP). (#)
MP6	6 meters, 2 computing units, 2 displays, 3 internal pumps. (#)

(\*) Narrow housing.

(#) Wide housing.

Software versions: P29403 for model MD6-1(\*\*); and  
P29232 for all other models.

(\*\*) Using a single stage valve pulsating to achieve the required pre-set price.

## TEST PROCEDURE No 5/6A/91B

Instruments shall be tested in accordance with any relevant tests specified in the National Instrument Test Procedures.

Tests should be conducted in conjunction with any tests specified in the approval documentation for any components used, including the indicator/controller and submersible turbine pump (STP) hydraulic systems.

The instrument shall not be adjusted to anything other than as close as practical to zero error, even when these values are within the maximum permissible errors.

### **Maximum Permissible Errors**

The maximum permissible errors are specified in Schedule 1 of the *National Trade Measurement Regulations 2009*.

### **Hose Configuration:**

#### L or LL housing, Dual Hose model (Figure 30)

Laser Frame - where the serial number on the data plate is 1234, hose A1 will have the serial number 1234A1

#### L or LL housing, Quad Hose model (Figure 31)

Laser Frame - where the serial number on the data plate is 1234, hose A1 will have the serial number 1234A1

#### MR or MMR housing, Dual Hose model (Figure 32)

Master Frame - where the serial number on the data plate is 1234, hose A1 will have the serial number 1234A1

#### MR or MMR housing, Quad Hose model (Figure 33)

Master Frame - where the serial number on the data plate is 1234, hose A1 will have the serial number 1234A1

#### PR or PPR housing, Dual Hose model (Figure 34)

Premier Frame - where the serial number on the data plate is 1234, hose A1 will have the serial number 1234A1

#### PR or PPR housing, Quad Hose model (Figure 35)

Premier Frame - where the serial number on the data plate is 1234, hose A1 will have the serial number 1234A1

#### Legend series, Dual Hose model (Figure 36)

Legend Frame - where the serial number on the data plate is 1234, hose A1 will have the serial number 1234A1

#### Legend series, Quad Hose model (Figure 37)

Legend Frame - where the serial number on the data plate is 1234, hose A1 will have the serial number 1234A1

#### Legend series, Six Hose model (Figure 38)

Legend Frame - where the serial number on the data plate is 1234, hose A1 will have the serial number 1234A1

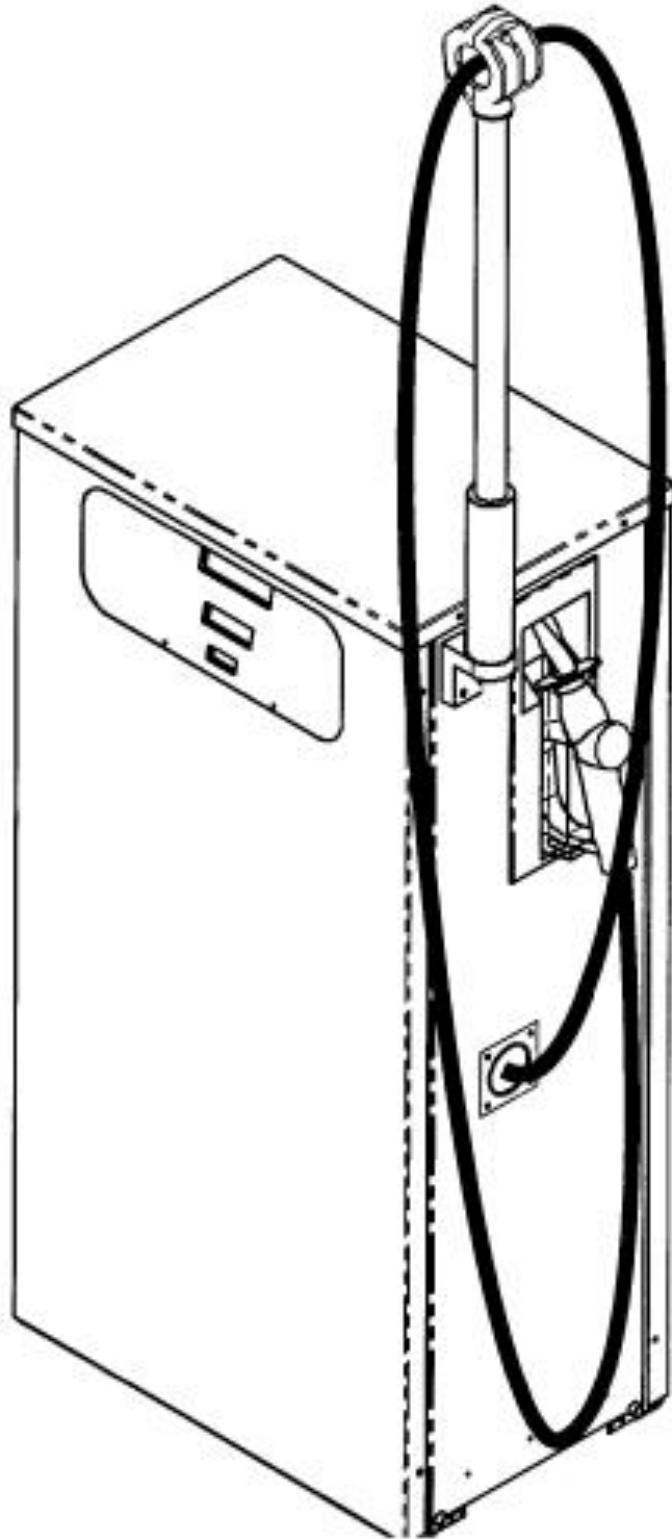
#### L or LL housing, Quad Hose model with DEF (Figure 39)

Laser Frame - where the serial number on the data plate is 1234, hose A1 will have the serial number 1234A1

#### MR or MMR housing, Quad Hose model with DEF (Figure 40)

Master Frame - where the serial number on the data plate is 1234, hose A1 will have the serial number 1234A1

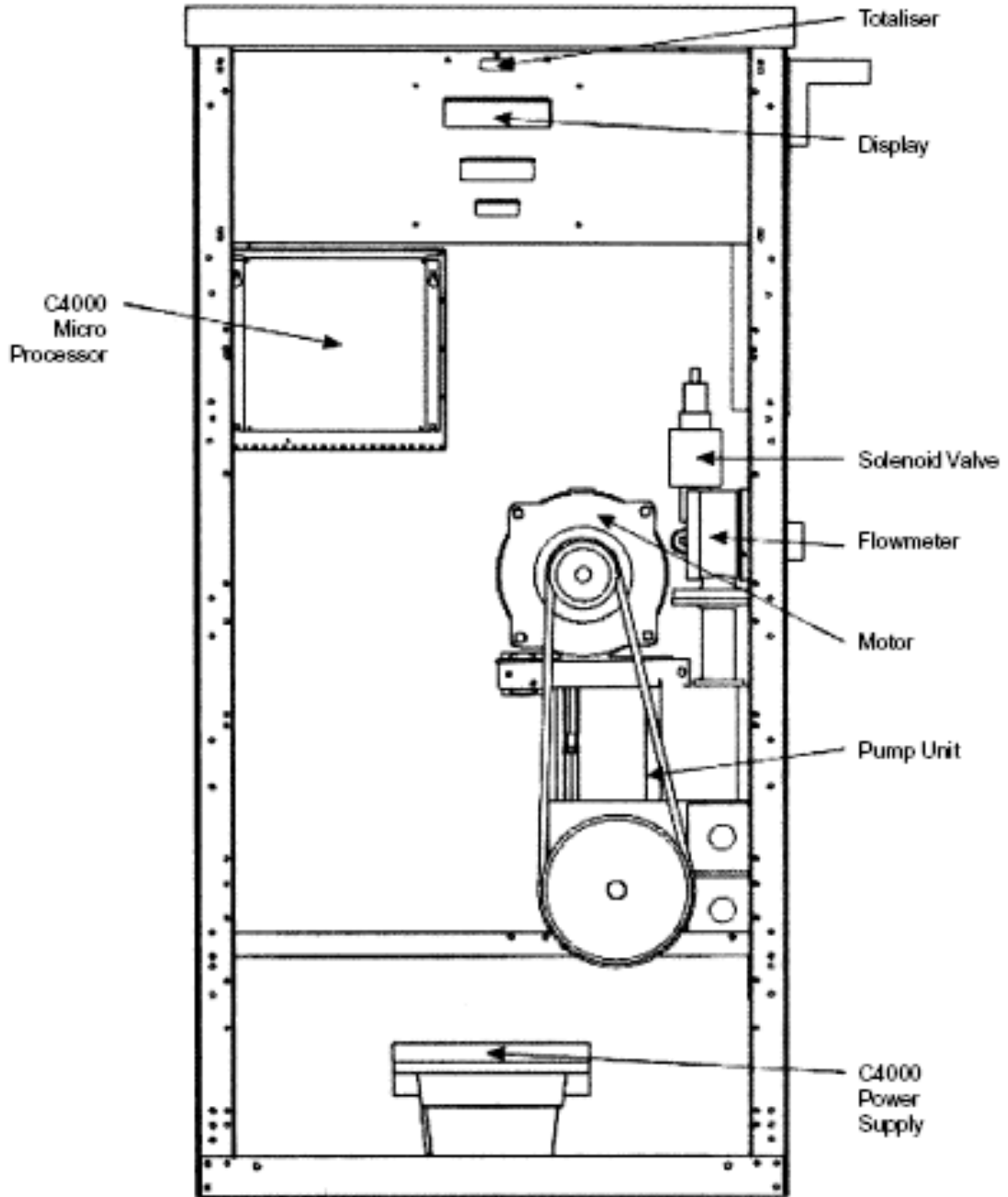
FIGURE 5/6A/91B – 1



Compac Industries Model MR40P Fuel Dispenser for Motor Vehicles – The Pattern



FIGURE 5/6A/91B – 2



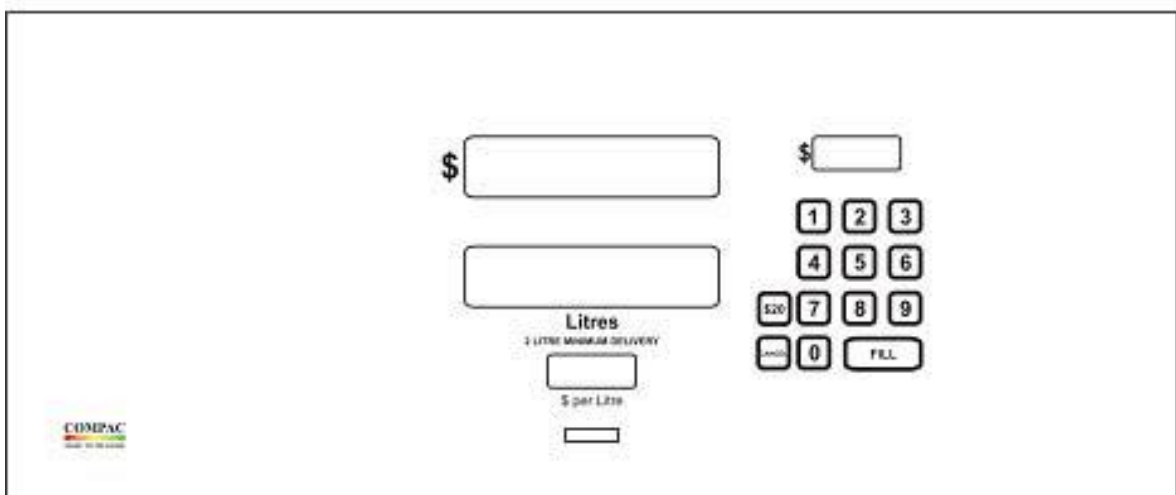
Model MR40P Dispenser Without Covers – The Pattern

FIGURE 5/6A/91B – 3



Model COM-50 (or COM-50S) Flowmeter – The Pattern

FIGURE 5/6A/91B – 4



Pre-set Facilities – Separate Pre-set Box or Integrated on the Indicator

FIGURE 5/6A/91B – 5



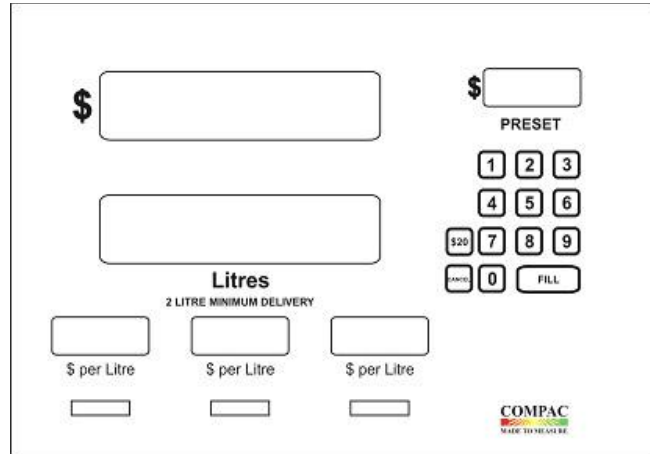
Model C4000 Calculator – The Pattern

FIGURE 5/6A/91B – 6



Single Hose C4000 Retail Indicator – The Pattern

FIGURE 5/6A/91B – 7



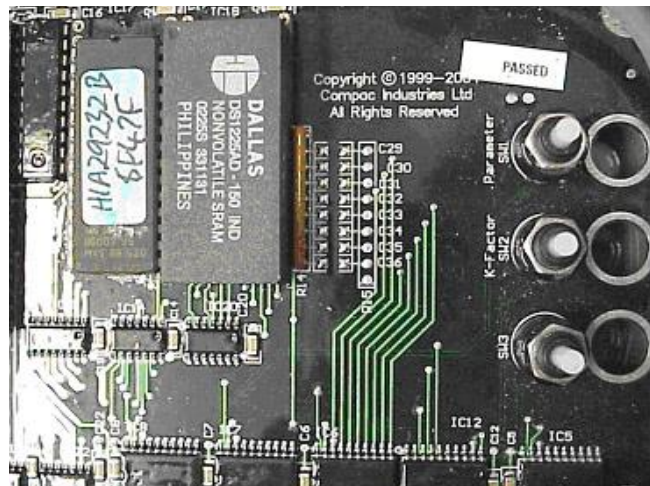
C4000 Retail Indicator With Pre-set

FIGURE 5/6A/91B – 8



Volume Only Display – The Pattern

FIGURE 5/6A/91B – 9



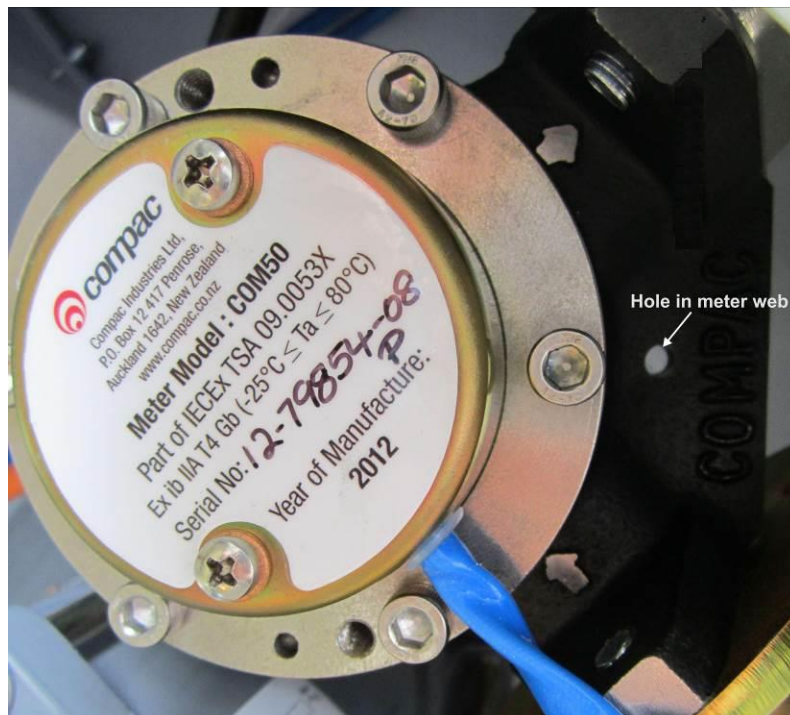
C4000 Parameter and K-factor Switches



FIGURE 5/6A/91B – 10



(a) The gas separator test valve



(b) The meter (using the hole in the meter web)

FIGURE 5/6A/91B – 11



Model LL40PQ Dispenser – Variant 1

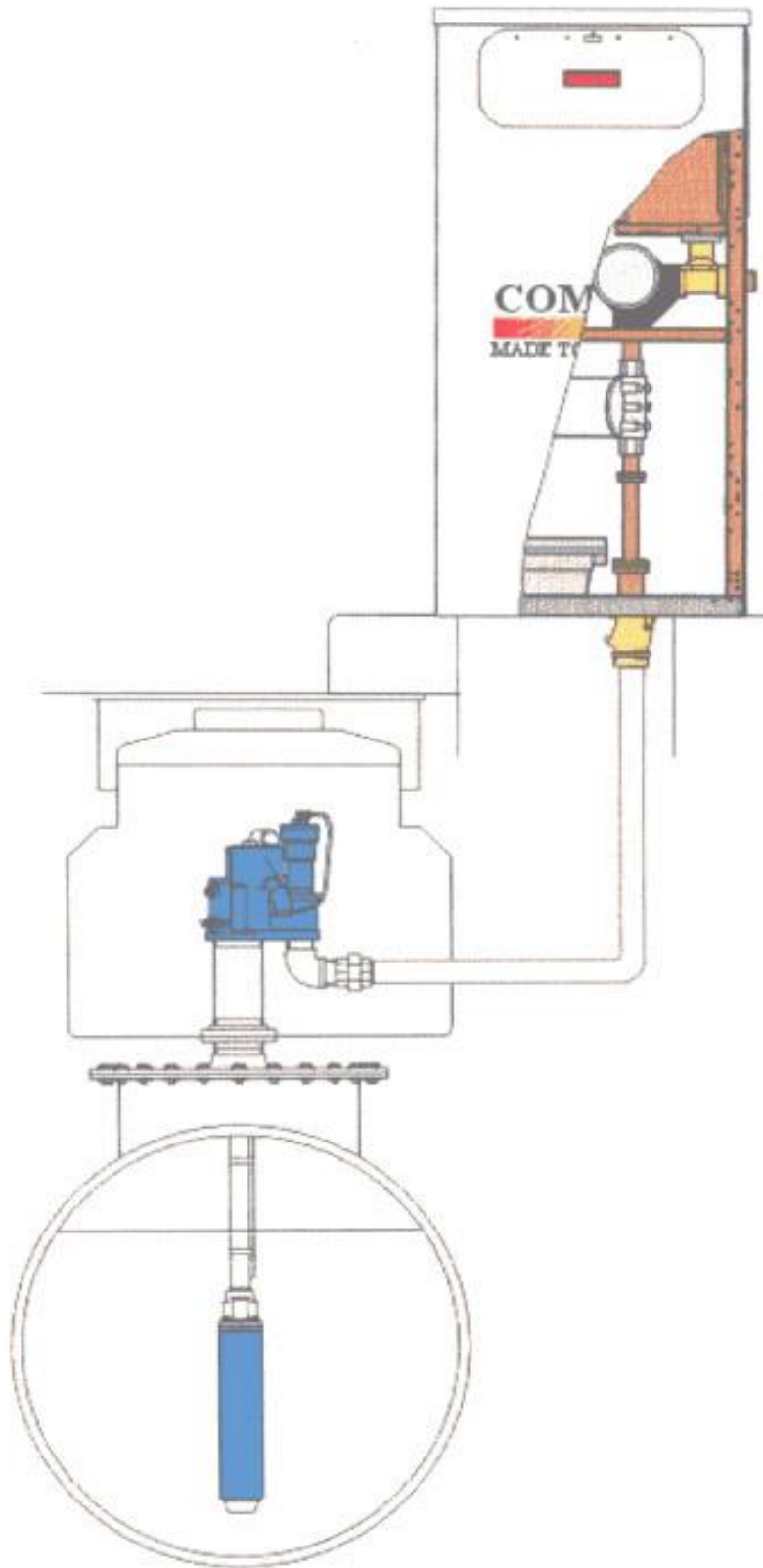
FIGURE 5/6A/91B – 12



Model LEGEND MP6 Dispenser – Variant 1

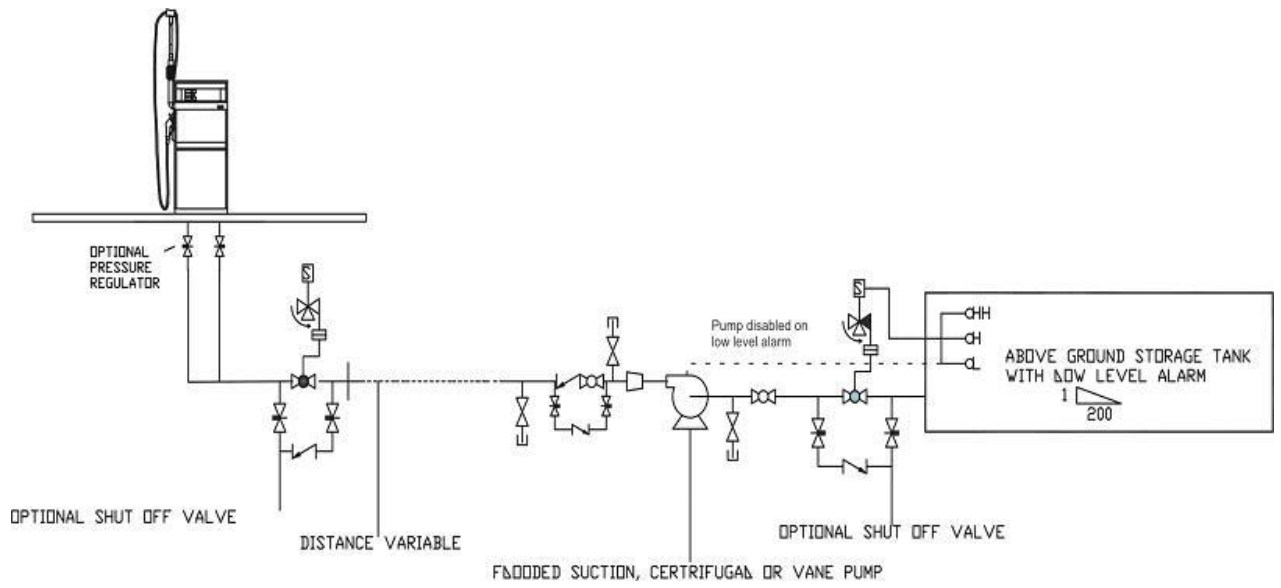


FIGURE 5/6A/91B – 13



Typical Submersible Turbine Pump System – Variant 2

FIGURE 5/6A/91B – 14



With External Pump and Above-ground Supply Tank – Variant 3

FIGURE 5/6A/91B – 15



Model MR160SD With Two COM125 Flowmeters – Variant 5

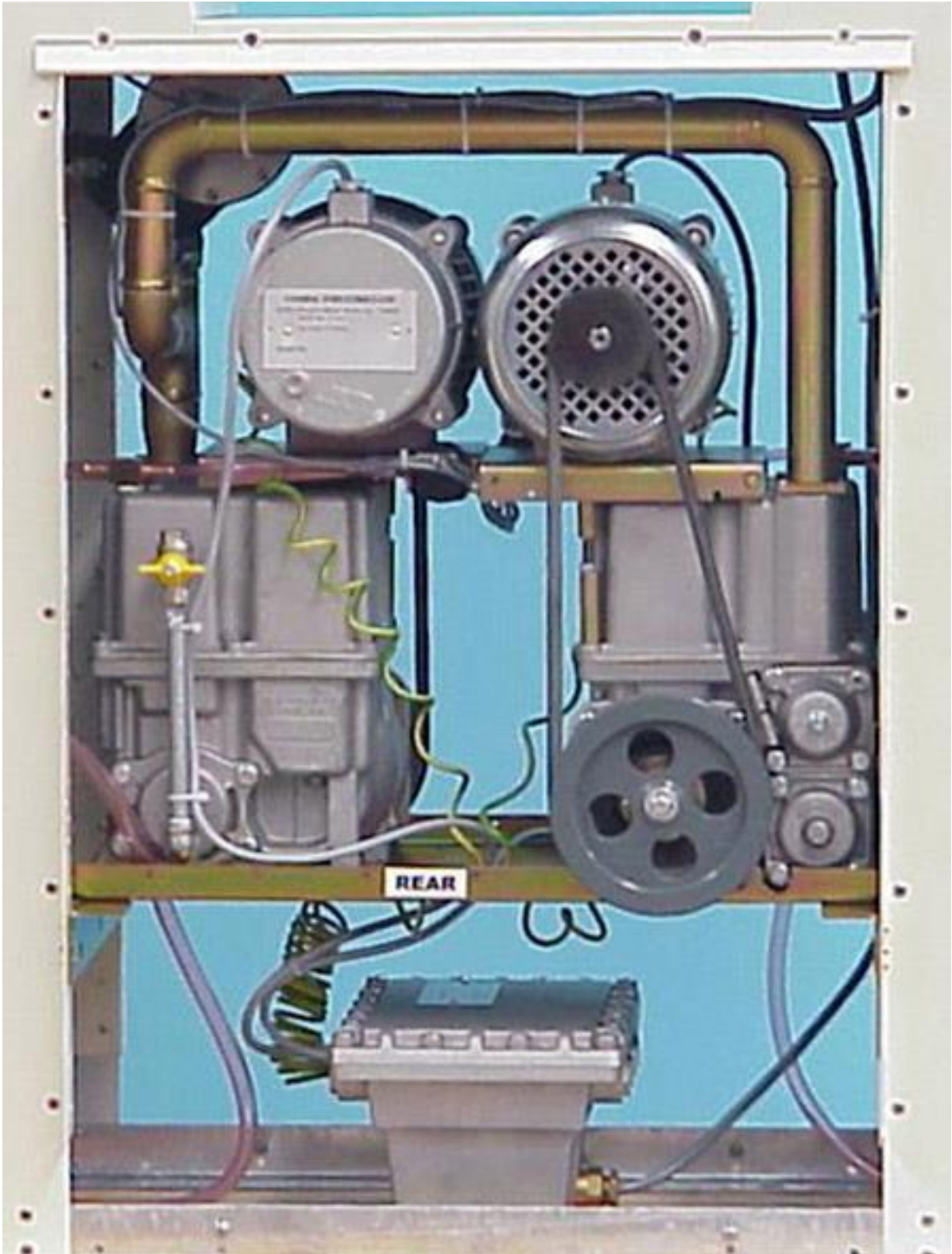
FIGURE 5/6A/91B – 16



Model MR160P With COM125 Flowmeter and Dual Pumps – Variant 5

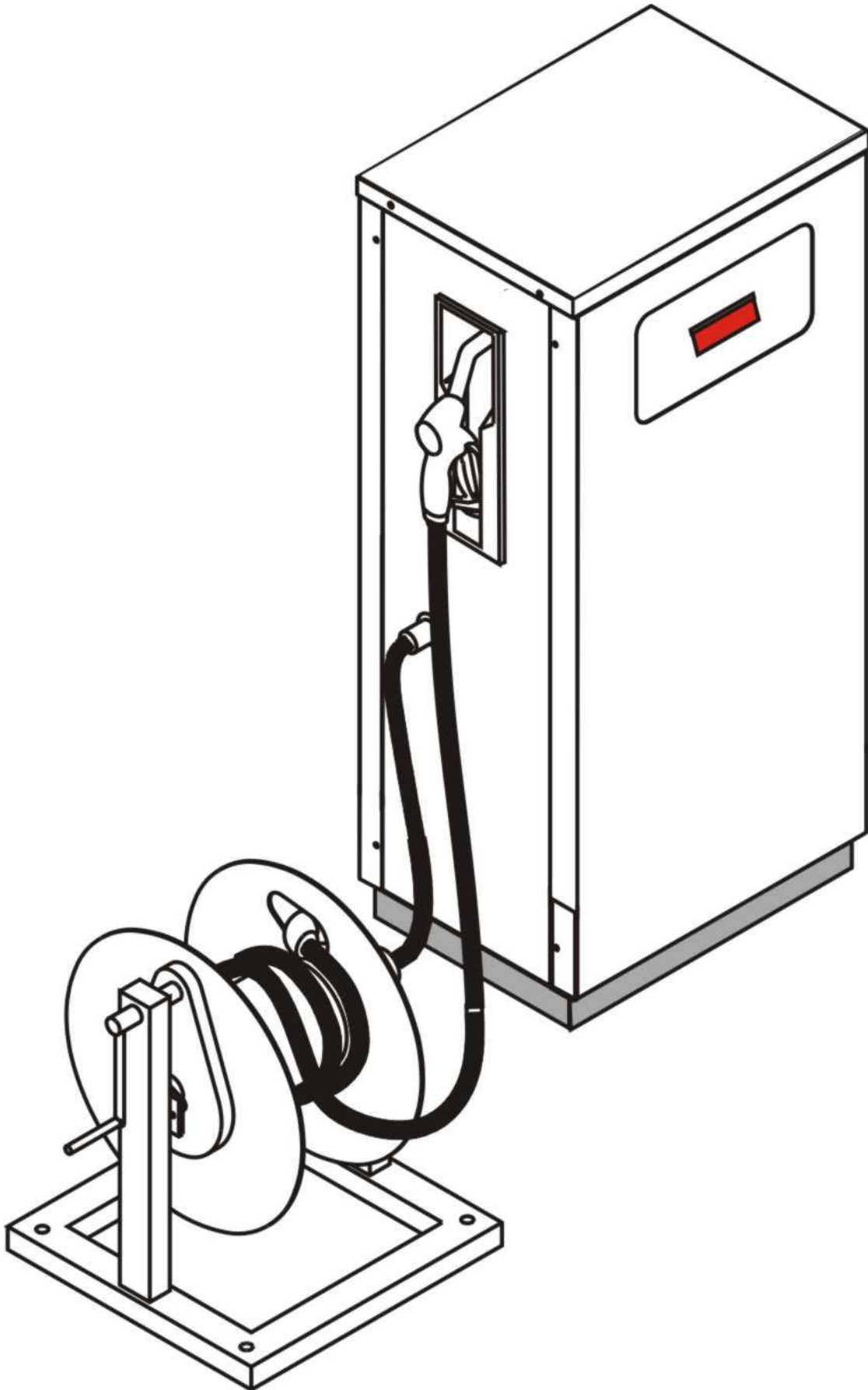


FIGURE 5/6A/91B – 17



Model L160P With COM125 Flowmeter and Dual Pumps – Variant 5

FIGURE 5/6A/91B – 18



Master Series – Model MR80P With Typical Hose Reel – Variants 5 and 6

FIGURE 5/6A/91B – 19



Typical Pump Selector Switch Location – Variant 5

FIGURE 5/6A/91B – 20



Typical LL Series Dispenser With External Filter – Variant 7



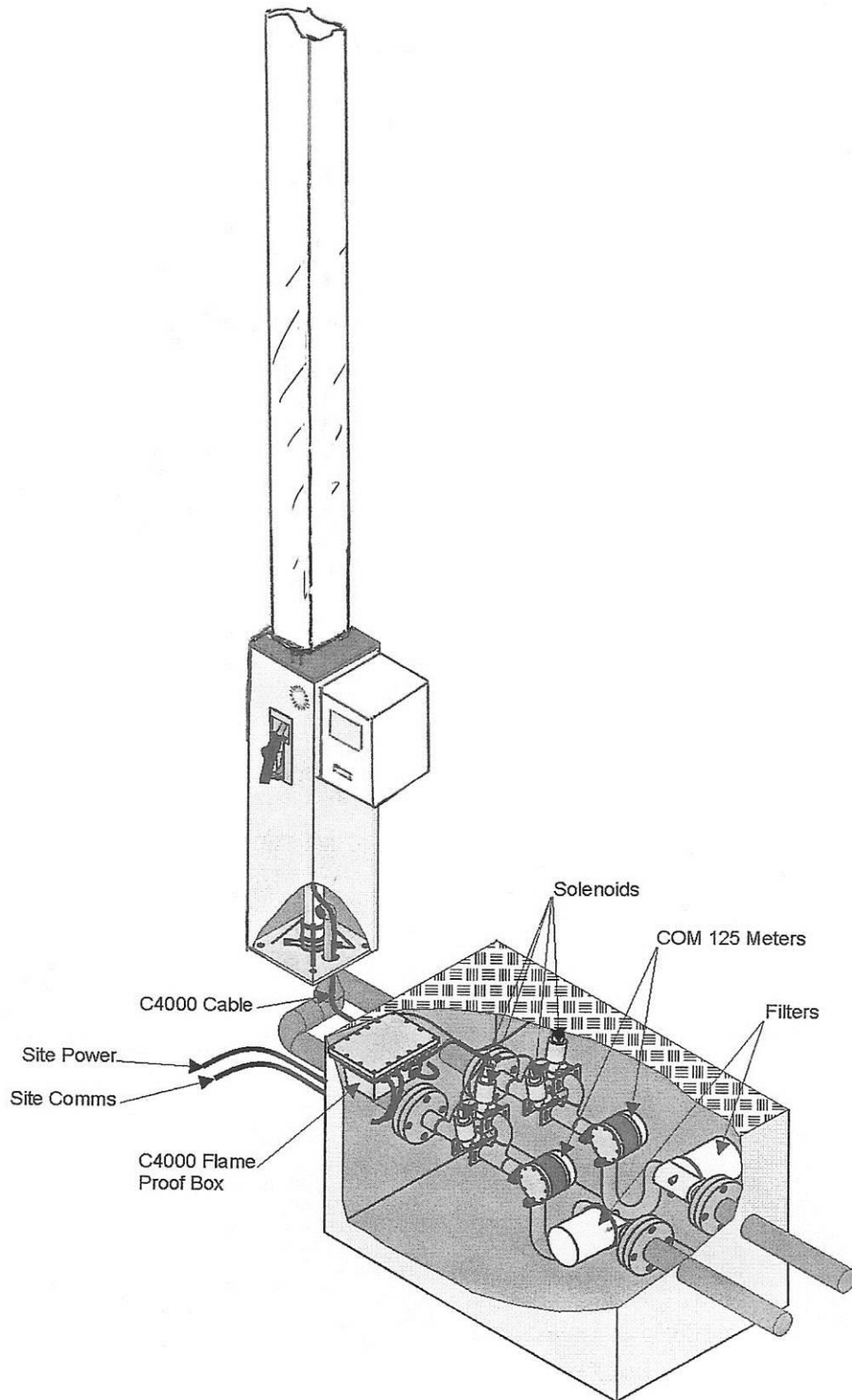
FIGURE 5/6A/91B – 21



Typical External Filter Installation – Variant 7

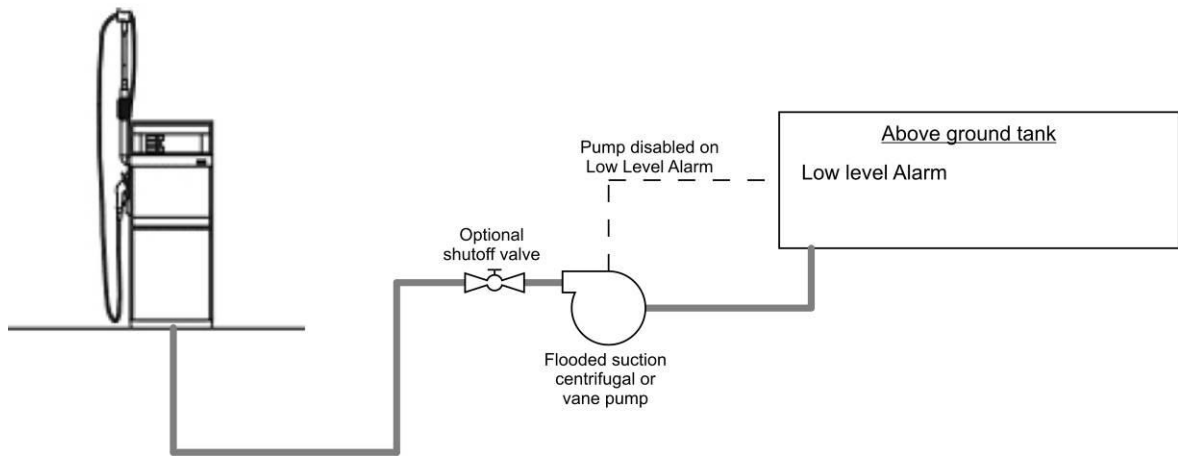


FIGURE 5/6A/91B – 22



Typical UR Series Dispenser Showing Underground Hydraulics – Variant 10

FIGURE 5/6A/91B – 23



(a) Compac Diesel Exhaust Fluid (DEF) Dispensing System – Typical Installation – Variant 11



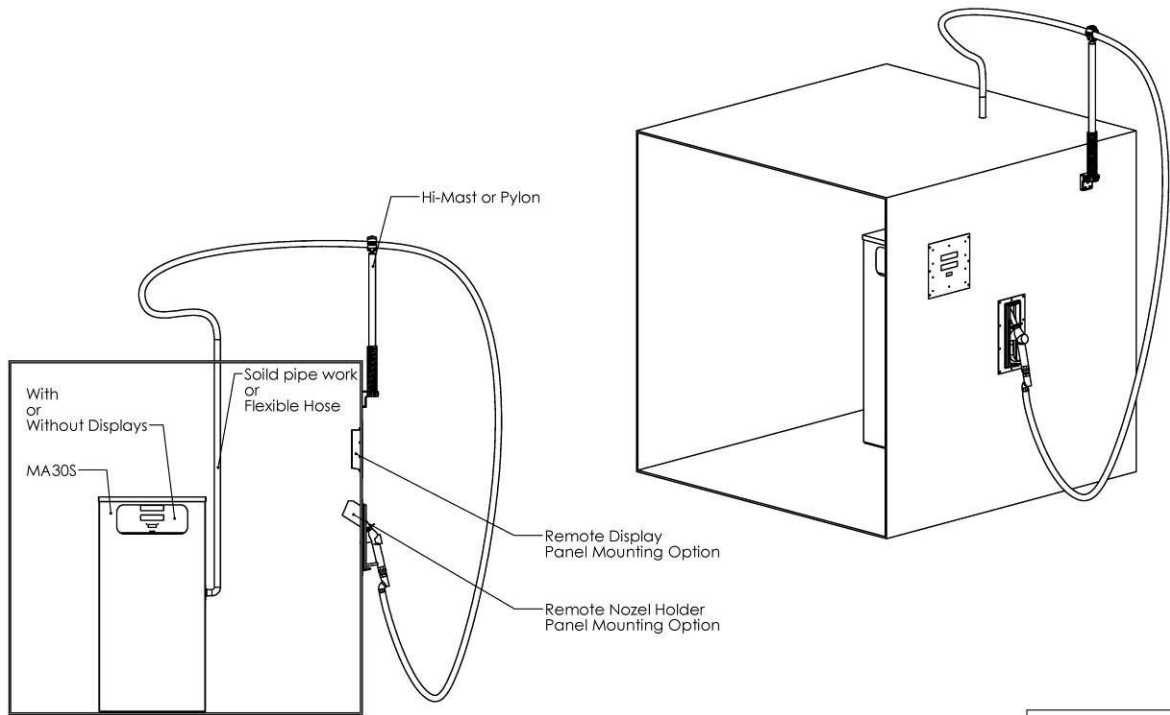
(b) Compac Diesel Exhaust Fluid (DEF) Dispenser Hydraulics – Variant 11

FIGURE 5/6A/91B – 24

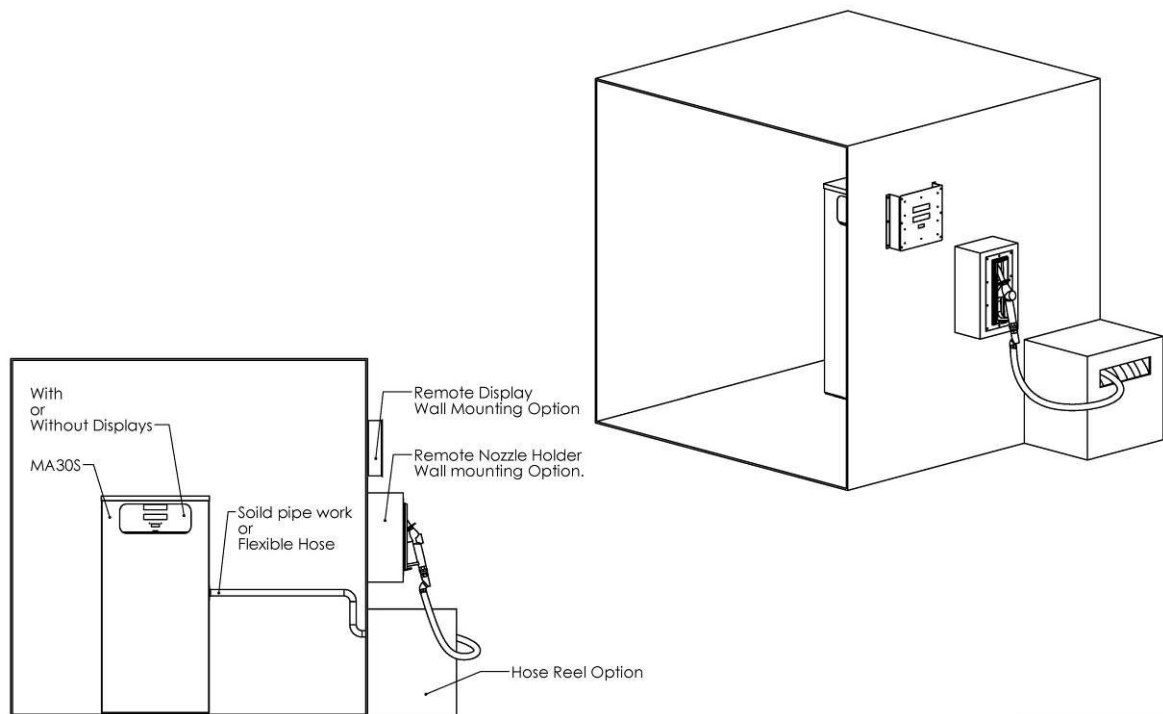


Compac Model KG-40 Mass Flowmeter – Variant 11

FIGURE 5/6A/91B – 25



(a) Remote Nozzle Holder and Display with High Mast Option



(b) Remote Nozzle Holder and Display with Hose Reel Option

FIGURE 5/6A/91B – 26



Compac Dispenser With ComFutra Option – Variant 13

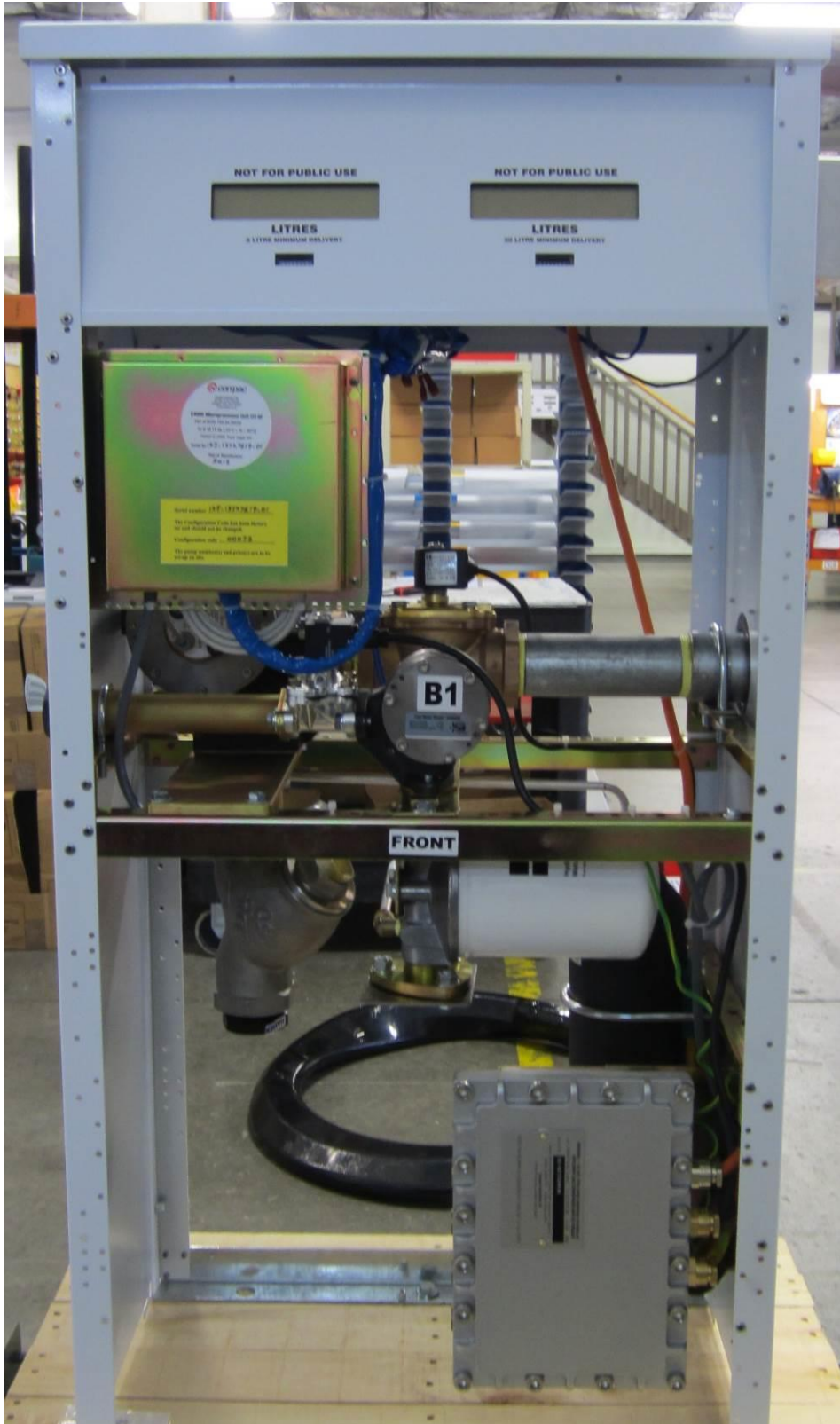
FIGURE 5/6A/91B – 27



Compac Dispenser With Cardking Option – Variant 14



FIGURE 5/6A/91B – 28



Dual Hydraulics – Variant 15

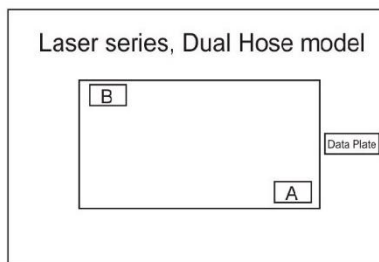
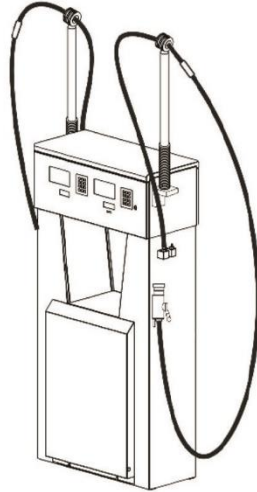
FIGURE 5/6A/91B – 29



Compac Model V50 Flowmeter – Variant 17

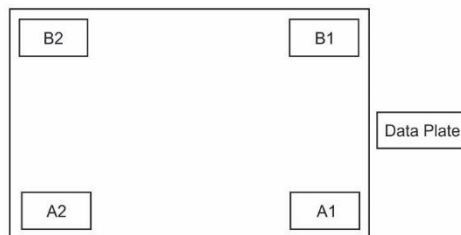
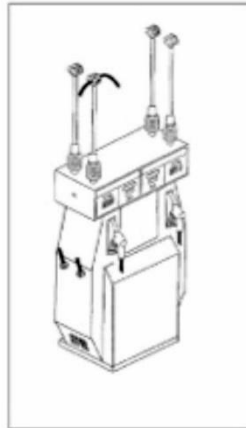


FIGURE 5/6A/91B – 30



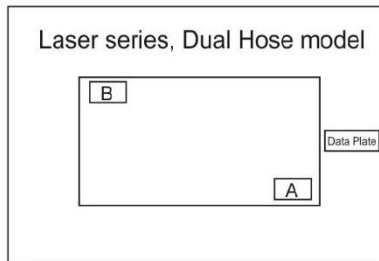
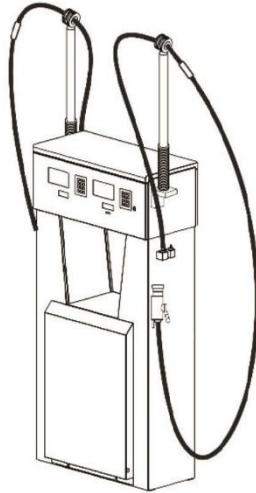
L or LL housing, Dual Hose model

FIGURE 5/6A/91B – 31



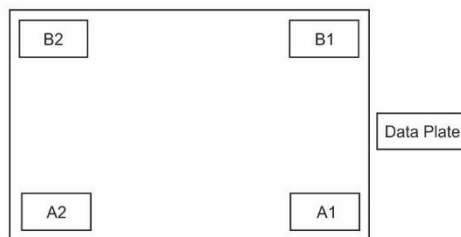
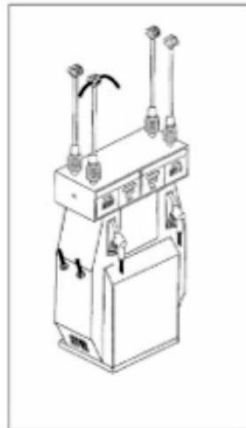
L or LL housing, Quad Hose model (also see Figure 39)

FIGURE 5/6A/91B – 32



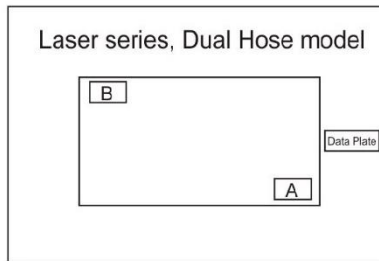
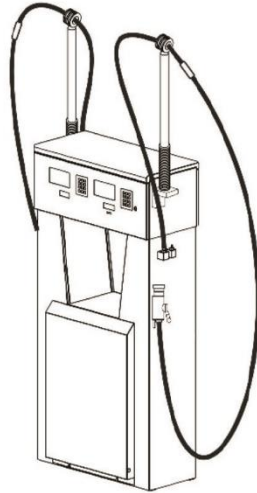
MR or MMR housing, Dual Hose model

FIGURE 5/6A/91B – 33



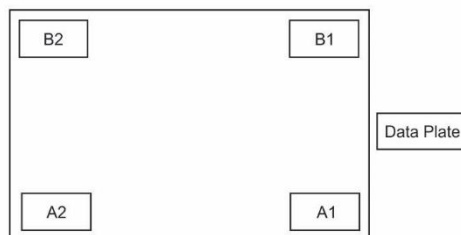
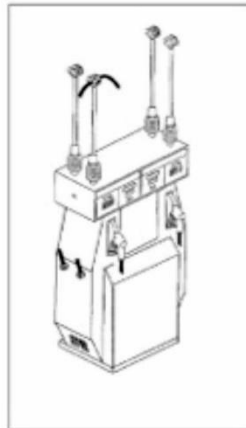
MR or MMR housing, Quad Hose model (also see Figure 40)

FIGURE 5/6A/91B – 34



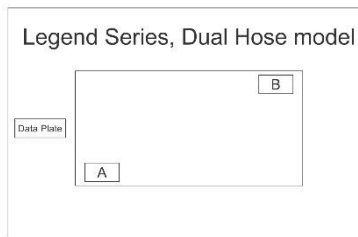
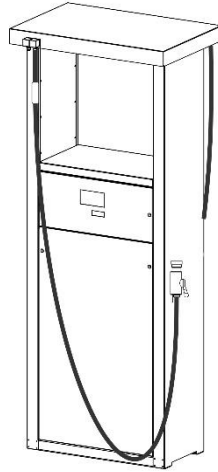
PR or PPR housing, Dual Hose model

FIGURE 5/6A/91B – 35



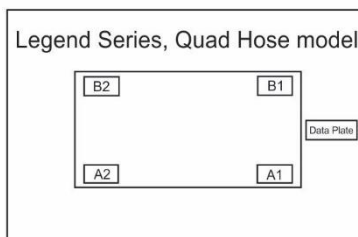
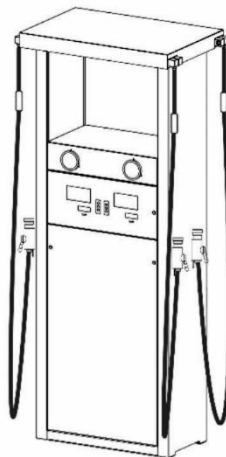
PR or PPR housing, Quad Hose model

FIGURE 5/6A/91B – 36



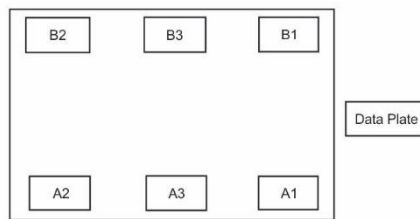
Legend series, Dual Hose model

FIGURE 5/6A/91B – 37



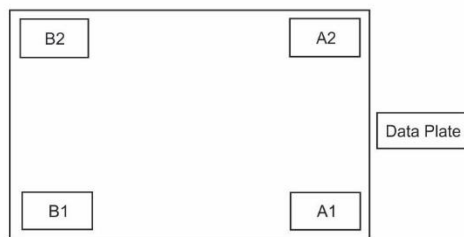
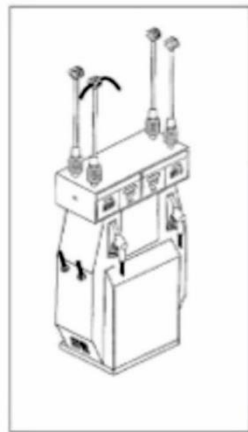
Legend series, Quad Hose model

FIGURE 5/6A/91B – 38



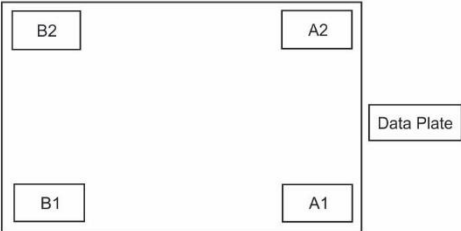
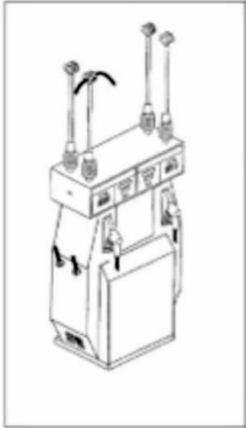
Legend series, Six Hose model

FIGURE 5/6A/91B – 39



L or LL housing, Quad Hose model  
(LLA30-160SQ; LLA30-80SQ; LLA30-40SQ)

FIGURE 5/6A/91B – 40



MR or MMR housing, Quad Hose model  
(MMA30-160SQ; MMA30-80SQ; MMA30-40SQ)

FIGURE 5/6A/91B – 41



Compac COM-50 flowmeter with anodised aluminium housing (Variant 18)

~ End of Document ~