



# ComTank

Designed for pump or dispenser control on above ground storage tanks, the ComTank offers a simple, secure solution to fuel management.



# The ComTank makes unattended refuelling and management of refuelling data a simple, straight forward process.

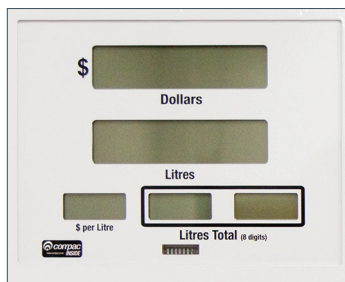

With the option of a remote mountable display and nozzle holster, refuelling is more convenient and accessible.



### System Features

- On-tank installation
- Diesel only
- Commercial or retail display
- Remote mountable additional display
- Single or dual hose
- Remote mountable nozzle holsters
- Hi/lo switch for hose outlet
- Available with Compac or PEC comms

### Authorisation Options

- HID Tag
- Pin number
- Card reader

### Download Transactions

- USB stick
- CompacOnline

### Tank Gauging Interface Options

- Veeder-Root
- Franklin
- Colibri

→ **Dimensions of the ComTank**

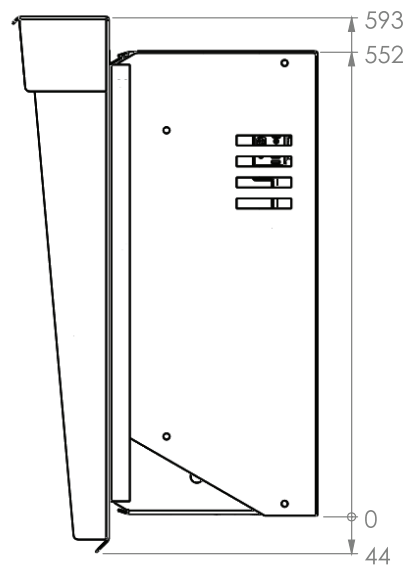
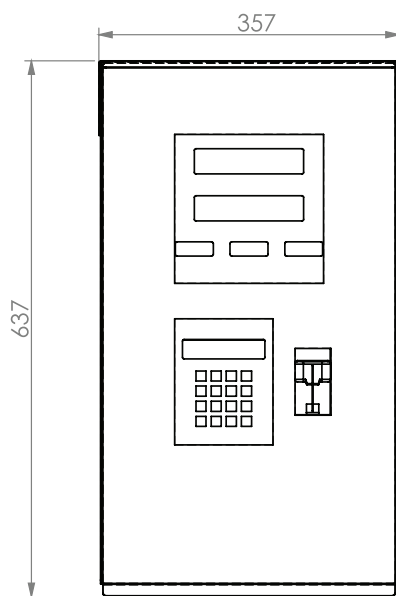
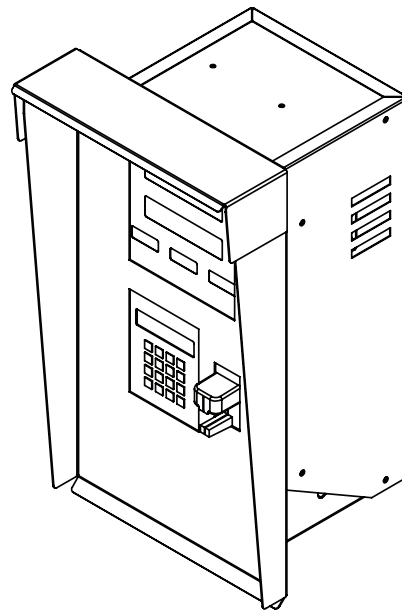
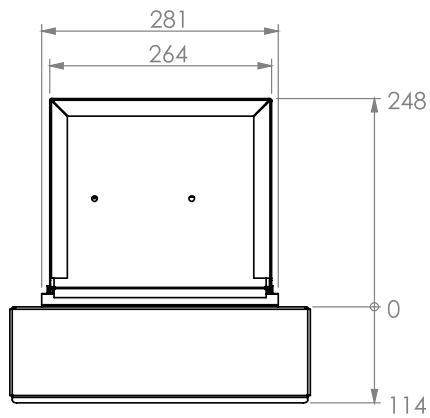

Cutout size to fit: 300mm x 575mm  
 Cutout template supplied for ease of installation

## CONTACT DETAILS



### **Compac Industries Ltd**

52 Walls Road, Penrose  
Auckland 1061  
New Zealand  
PO Box 12 417, Penrose  
Auckland 1642  
New Zealand  
Tel: +64 9 579 2094  
Fax: +64 9 579 0635  
[www.compacngv.com](http://www.compacngv.com)  
[www.compac.co.nz](http://www.compac.co.nz)

### **Compac Sales Pty Ltd**

32 Boundary St  
South Melbourne, VIC 3205  
Australia  
PO Box 312  
Port Melbourne, VIC 3207  
Australia  
Tel: +61 3 8696 4888  
Fax: +61 3 8696 4817  
[www.compacsales.com.au](http://www.compacsales.com.au)

### **Compac Industries India Ltd**

K 73 Udyog Nagar  
Main Rohtak Road  
Delhi - 110041  
India  
Mobile: +91 85888 78287  
[www.compacindia.com](http://www.compacindia.com)